CREATIVE CONTROL PRODUCTS

3185 Bunting Avenue, Grand Junction, CO 81504 - (303) 434-9405

UAD-100 UNIVERSAL AUDIO DELAY

OWNER'S MANUAL

COPYRIGHT (C) 1993 CCP

Creative Control Products reserves the right to revise this manual and to make changes at any time without obligation to notify any person of such changes or revisions.

LIMITED WARRANTY

Creative Control Products warrants that any new UAD-100 manufactured by Creative Control Products will be free from defects in components and manufacture for one year from date of purchase. Any accidental damage, misuse or improper installation voids all warranties.

Copyright (C) 1993 Creative Control Products

All rights reserved

Printed in the U.S.A.

UAD-100 UNIVERSAL AUDIO DELAY OWNER'S MANUAL

TABLE OF CONTENTS

1.0	Introduction	2
2.0	Specifications	3
3.0	UAD-100 Block Diagram	4
4.0	UAD-100 Board Layout	5
4.1	Interface Connector P1 (Pinout)	5
5.0	Power & Audio Interfacing	6
5.1	Interface Connector (P1)	6
5.2	Power	7
5.3	Audio Connection	7
5.4	UAI-10/20 Audio Interfacing	8
6.0	Logic Interfacing	9
6.1	Repeater COS Signal Input	9
6.2	DTMF Mute Signal Input	11
6.3	SRC-10 Modifications	12
7.0	Service	13
8.1	Troubleshooting	13
8.2	Repair Service	13
8.0	Schematic Diagram	14
9.0	Order Blank	15

CREATIVE CONTROL PRODUCTS

1.0 INTRODUCTION

The Creative Control Products UAD-100 Universal Audio Delay board is a low cost, easy to interface repeater audio delay circuit featuring complete DTMF tone mute, and squelch tail elimination.

The UAD-100 audio delay board delays the repeater receiver audio by 100 ms before it arrives at the repeater transmitter. This delay is adequate to mute the squelch tail in most repeater receivers.

The UAD-100 is inserted in the repeater receiver audio path before any audio switching circuitry. With the UAD-100 installed and no COS activity, the repeater receiver audio path is muted. No audio will pass between the repeater receiver to the repeater transmitter. When the repeater COS activates the audio path is opened with a delay allowing the receiver audio to flow to the transmitter. When the repeater receiver loses COS, the receiver mutes the squelch tail before the receiver squelch closes, resulting in a pleasant sounding transmitter drop. No crashing, clunking or snap is heard.

When interfaced to a repeater controller with a active low DTMF mute output, the DTMF audio is fully muted out the repeater transmitter. No touch-tones or blips are heard.

Control inputs to the UAD-100 consist of repeater COS (which is selectable high or low), and an active low DTMF mute signal from your repeater controller.

The UAD-100 is the perfect answer for delaying the audio from your repeater receiver to your repeater transmitter, resulting in a great sounding system that is a pleasure to use.

A special version of the UAD-100 is available with a 200ms delay time, twice the standard delay. Please contact the factory for information & pricing.

CREATIVE CONTROL PRODUCTS

2.0 SPECIFICATIONS

SIZE: 2 1/8 by 3 1/4 inches.

MOUNTING: Four mounting holes for #6-32 screws.

POWER: +8 to 15 volts DC at 14ma typical.

OPERATING TEMPERATURE: -30 to +50 degrees C.

CONNECTOR: One 10 pin male in-line straight header.
Mating connector and pins supplied.

AUDIO DELAY TIME: Preset at 100ms, non adjustable.
200ms delay is available as an option.

AUDIO INPUTS: Repeater receiver which has an input
impedance of approximately 10K ohms.

AUDIO OUTPUTS: Output frequency response is filtered
with a bandpass filter from 300 to 3500
cycles. Output impedance is approximately
600 ohms.

DTMF MUTE INPUT: Active low (ground).

REPEATER COS INPUT: Selectable between an active low
(ground) or an active high (3 to 15
volts).

CREATIVE CONTROL PRODUCTS

3.0 UAD-100 BLOCK DIAGRAM

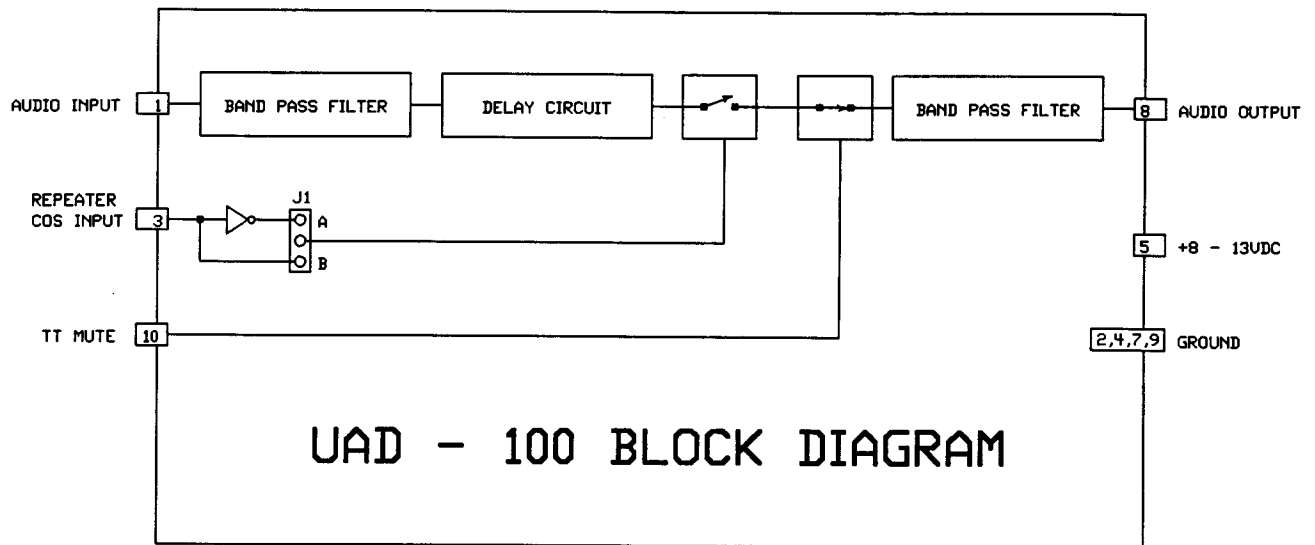

CREATIVE CONTROL PRODUCTS

4.0 UAD-100 BOARD COMPONENT LAYOUT

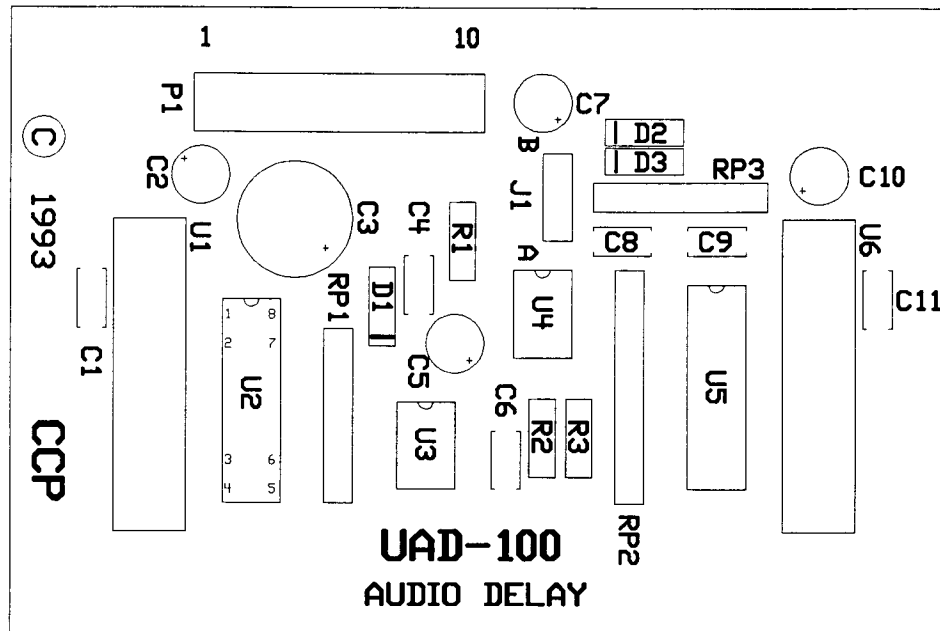

4.1 INTERFACE CONNECTOR (P1) PINOUT

1. Audio Input
2. Ground
3. Repeater COS Input
4. Ground
5. +8 to 15 Volts DC
6. No Connection
7. Ground
8. Audio Output
9. Ground
10. DTMF Mute Signal Input

CREATIVE CONTROL PRODUCTS

5.0 POWER & AUDIO INTERFACING

While interfacing the UAD-100 is fairly straight forward some clarification may be needed on a few points. It is assumed that all of the components of a typical repeater system share the same power supply ground potential or, in other words, all of the grounds from the various power supplies in the system are tied together.

All of the inputs and outputs of the UAD-100 are capacitively coupled therefore, the system designer needn't be concerned with matching DC levels on the inputs and outputs of the UAD-100 audio interface. Note, however, that ground pins (2,4,7,9) are provided for the audio signal inputs but no ground pins are provided for the audio signal outputs. The reason for the audio ground pins on the input and not the output is to provide shield connections at the high impedance point of each audio input. Note also, only one end of the audio lead shield should be connected to prevent any ground loop problems. The high impedance point on the output side of the UAD-100 audio board will most likely be at the transmitter or transceiver transmit audio input. Thus, the audio lead shield should be connected to a ground at the transmitter and not be connected at the UAD-100 to again, prevent ground loops in the audio circuit.

It is possible to interconnect the audio portion of the UAD-100 without using shielded audio cable. However, this depends a lot on the construction of the repeater and the environment in which the repeater will be operating. If there is any concern about your particular repeater application or operating environment, perhaps shielded audio cable for the audio connections would be well worth the additional effort and expense.

5.1 INTERFACE CONNECTOR (P1)

The ten pin interface connector (P1) is made up of a standard 10 pin straight in-line male header. This header use 0.10 inch center spacing and includes a friction lock for improved mated retention. A mating 10 pin female polarized connector is provided with the UAD-100. They are also available from Molex, part #22-01-3107.

5.2 POWER

The UAD-100 input voltage, +8 to 15 volts DC is connected to pin #5 on the interface connector P1. Power ground is applied to pin #4. The current draw is approximately 14ma at +13.8 volts input. As always, be careful not to reverse the input voltage polarity or damage will occur.

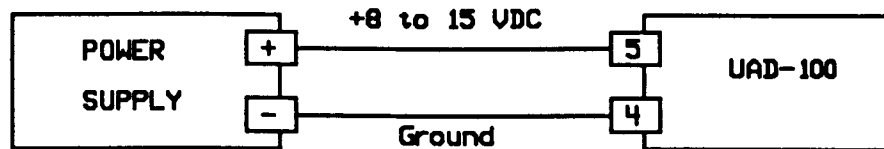

5.3 AUDIO CONNECTION

Audio input is connected to pin #1 on the interface connector (P1) with the shield connected to pin #2. Audio output is connected to pin #8. The UAD-100 is inserted before any audio switching circuitry located in the repeater receiver audio path. Because the UAD-100 impedance is 10K, it may be connected with minimum loading to the audio circuit. Optimum audio input should be between .25 and 1.0 volt peak to peak.

Many repeater controller boards already have a connector installed at the proper audio point for a audio delay board to be connected. Please refer to your controllers schematic diagram.

AUDIO CONNECTION

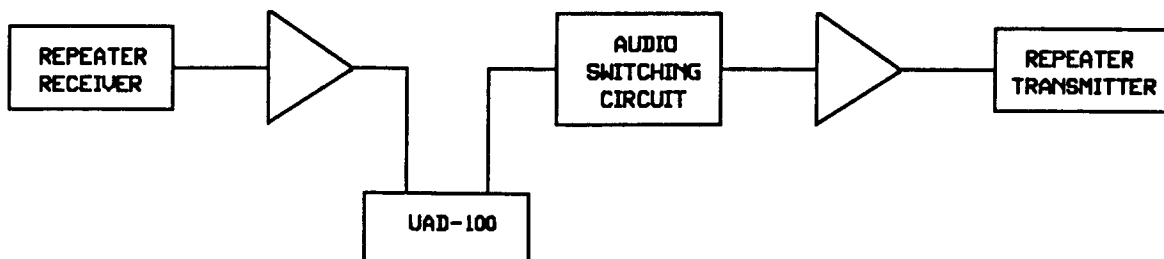

5.4 UAI-10/20 AUDIO INTERFACING

If you are interfacing the UAD-100 to a Creative Control Products UAI-10 or UAI-20 audio interface board, the following modifications must be performed.

On the UAI-10 or UAI-20, unsolder and remove the 8-pin resistor SIP (RP3) from the circuit board and carefully cut off the last resistor, pins 7 and 8 in the SIP package. Reinstall and solder RP3, holes 7 and 8 should be open. Locate pin #1, audio input from the UAD-100 and connect to where RP3 pin 8 was. Next take pin #8, audio output from the UAD-100 and connect a 10K ohm resistor in series to where RP3 pin 7 was. This completes all modifications needed to interface the UAD-100 audio delay board to either Creative Control products UAI-10 or UAI-20 audio interfaces.

Remove RP3 resistor
pins 7 and 8.

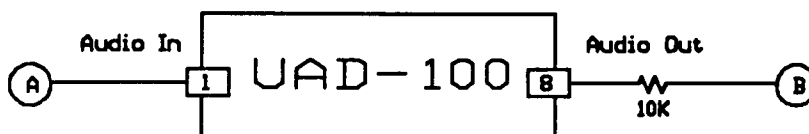
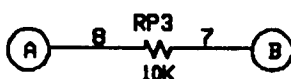

Install UAD-100 where RP3 resistor
pins 7 and 8 were.

CREATIVE CONTROL PRODUCTS

6.0 LOGIC INTERFACING

The logic connections of the UAD-100 may require some special attention depending on the type of controller the UAD-100 will be used with. The DTMF MUTE and REPEATER COS inputs were designed to be used with the SRC-10 repeater controller with only minor modifications. If a controller of other manufacture is used, the following guidelines should be heeded.

6.1 REPEATER COS SIGNAL INPUT

The Repeater COS (Carrier Operated Switch) signal is produced by a circuit in your repeater receiver. It is connected to pin #3 on the UAD-100 interface connector P1. This input can be configured to activate with either a high or low signal.

The UAD-100 repeater COS signal is designed to operate with an active high repeater COS signal (greater than 3 volts in the active state) or an active low repeater COS signal (approximately ground or 0 volts in the active state). The only requirements on the repeater COS signal are that the voltage levels mentioned above be adhered to, the repeater COS signal input must not be allowed to float, and the Repeater COS Signal itself must have a relatively quick rise time. See Figure 6-1 for some representative repeater COS signal input circuits.

The input desired is achieved by jumpering the correct combination on the user programmable input header J1 (Figure 6-2). For a high input voltage, jumper header (J1) to the "B" position. In this configuration, a voltage from +3 to 15 volts is acceptable, with the logic threshold between 2 and 3 volts. Inputs less than 3 volts may or may not trigger the input. For a low input, jumper header (J1) to the "A" position. Here the signal needs to be a low (ground) to activate the logic.

If you are not sure at which level your receiver COS operates, measure the voltage at the receive COS output with the receiver squelch open.

COS Input Circuits

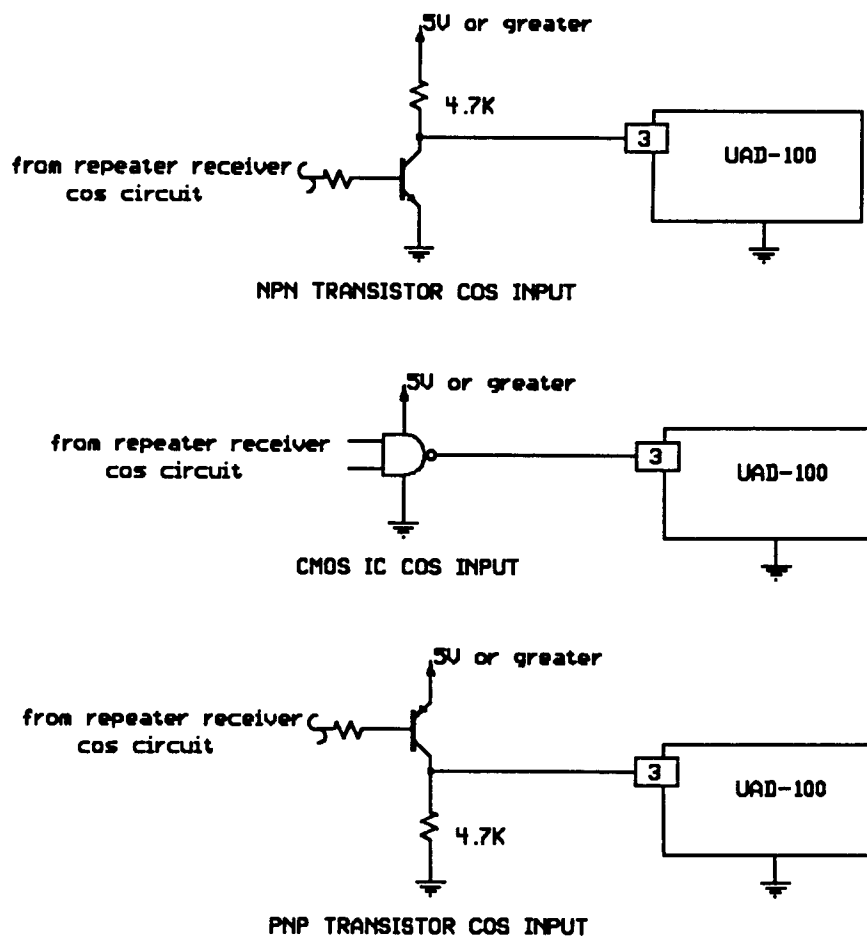

Figure 6-1

Programmable COS Jumper J1

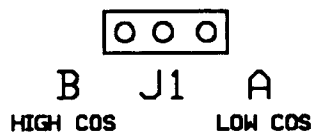

Figure 6-2

6.2 DTMF MUTE SIGNAL INPUT

The DTMF Mute signal is provided by the repeater controller and is connected to pin #10 on the interface connector P1. An active low (ground) is required to activate this function. Whenever the input is activated, the repeater receive audio is muted so that no DTMF tones are present at the repeater transmit output.

The DTMF Mute input is enabled when pulled low (ground) and is designed to be used with an open collector transistor, open drain power FET, or integrated circuit which has outputs utilizing these type devices. If another logic family is used to drive this input it MUST, in the high state (+V), swing to a minimum of 2/3 the voltage used to power the UAD-100 which is connected to pin #5 of the UAD-100 interface connector. The users controller may have a much higher high state (+V) voltage than 2/3 the voltage used to power the UAD-100 on an output designated to drive the UAD-100 DTMF Mute input but never must the voltage be lower. Also, the voltage must be lower than 1/3 of the UAD-100 power supply voltage when in the low (ground) state. Usually, the simplest, safest, and most effective solution will be to add an npn transistor to the line controlling the UAD-100 DTMF Mute input as depicted in Figure 6-3.) Again, if the UAD-100 is to be used with the SRC-10 repeater controller, only slight modifications are required.

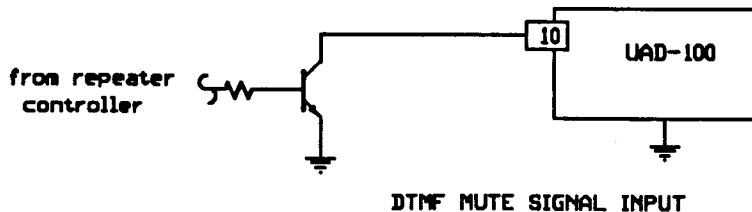

Figure 6-3

6.3 SRC-10 MODIFICATIONS

When interfacing the UAD-10 audio delay board to a Creative Control Products SRC-10 smart repeater controller, a small modification must be performed to allow the DTMF audio to fully mute.

On the SRC-10 carefully remove IC U8 (4069) from it's socket and clip pins 3 and 4 from the IC. Next, either solder a bridge on the bottom side of the circuit board between pins 3 and 4 of IC U8 or install a small jumper wire between pins 3 and 4 in the IC socket. If you install the jumper, be careful the pins you cut off of the IC don't touch the jumper when the IC is inserted back in the socket. Be sure to insert IC U8 back in it's socket so that pin 1 is oriented properly.

This completes all modifications needed to the SRC-10 smart repeater controller.

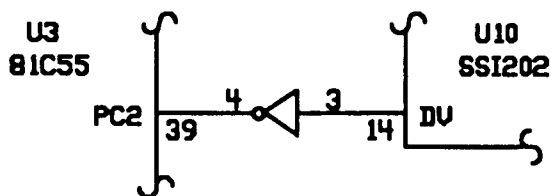

SRC-10 repeater controller before modification.

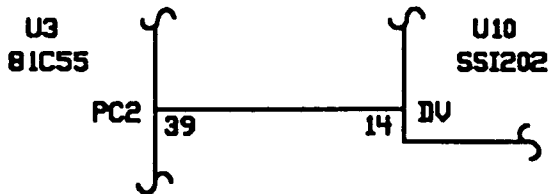

SRC-10 repeater controller after modification.

CREATIVE CONTROL PRODUCTS

7.0 SERVICE

7.1 TROUBLESHOOTING

Because the UAD-100 is designed with quality components, a component failure that would take the unit out of service is unlikely. The only maintenance recommended is that the interface connector be checked periodically for any broken or frayed connections.

If the UAD-100 fails to perform specific functions, ensure that the COS jumper is installed correctly and that there are no hot components or IC's. If operation totally fails, check to see if the input voltage is adequate. Since all IC's are socketed, troubleshooting and repair should be moderately easy. A general checklist to follow is as follows:

- * Input voltage between +8 and 15VDC
- * All grounds connected
- * IC's seated in sockets
- * Interface connector firmly connected
- * No hot components
- * COS input operating correctly
- * COS jumper correctly installed
- * DTMF mute signal operating to ground

7.2 REPAIR SERVICE

If your UAD-100 needs to be returned for repair, contact the factory before shipping so that a Repair Authorization Number (RA#) can be issued. This will help keep track of your board and speed repair time. Please include a letter explaining the problem in detail, along with your name, callsign, address and phone number.

8.0 SCHEMATIC DIAGRAM

